

IMECE2008-66803

A STUDY ON SUSTAINABLE ENERGY SOURCES & ITS CONVERSION SYSTEMS TOWARDS DEVELOPMENT OF AN EFFICIENT ZERO POLLUTION NOVEL AIR TURBINE TO USE AS PRIME- MOVER TO THE LIGHT VEHICLE

Bharat Raj Singh

Department of Mechanical Engineering
Sagar Institute of Technology & Management
Barabanki-225001, U.P., INDIA
Tel: +91-524-822-0001, Fax: +91-524-822-0003
E-mail:brsinghko@yahoo.com

Onkar Singh

Department of Mechanical Engineering
Harcourt Butler Technological Institute
Nawabganj, Kanpur-208002, U.P., INDIA
Tel: +91-941-511-4011, Fax: +91-512-253-3812
E-mail: onkpar@rediffmail.com

ABSTRACT

Greater use of hydrocarbon fuel has led to fast depletion of fossil fuel reserves. This has now become worldwide problem making civilization vulnerable due to paucity of fuel in future. It is also a fact that as civilization is growing the use of transport has become essential part of life. The use of large number of vehicles for transport is contributing to about 70% of total air pollution, creating environmental & ecological imbalances. About 100-150 years old transport technology is totally based on combustions causing higher rate of emission, ultimately depleting the thickness of Ozone layer and causing the global warming. Thus worldwide fast depletion of conventional energy resources necessitates the search of alternatives such as Non- Conventional Energy Sources, Renewable Energy Sources and other Direct Conversion of Energy Sources. This paper deals with study on potential of renewable energy resources and their conversion system with emphasis on development of zero pollution engine for vehicles which may lead to sustainable future.

Keywords: fossil fuel, pollution, emission, depletion, energy source, energy conversion.

1.0 INTRODUCTION

Worldwide depletion of conventional energy resources is necessitating the search of alternatives resources such as Non- Conventional and Renewable Energy Sources, for sustainable future energy sources. As per recent study, about 80 % of fossil fuel is being consumed in transport (e.g., Cars, Buses, Trucks, Trains, Power plants, Room heating devices etc.). In 1956, an US based Chief Consultant and Oil Geologist Marion King Hubbert [1] predicted that if oil is consumed with high rate, US Oil production may peak in 1970 and thereafter it will decline. It was also predicted that other countries may attain Peak Oil day within 20-30 years and many more may suffer with oil crises within 40 years, when Oil wells are going to dry. Thus the peak oil year may be the turning point for mankind which in turn will lead to the end of 100 years of easy growth, if sustainability of energy [2] is not maintained on priority.

On other hand, the vehicular pollution is estimated to have increased eight times over the last two decades and contributes about three quarter of the total pollution especially in India. With 243.3 million tons of carbon released from the consumption and combustion of fossil fuels

in 1999, India is ranked fifth in the world after the U.S., China, Russia and Japan. India's contribution to world carbon emissions is expected to increase in the coming years due to rapid migration of population to urban area thereby increasing vehicular usage and also due to continued use of older and more inefficient coal-fired and fossil fuel power-plants.

India is developing country and average income per person is very low to meet out the minimum requirement of person. Maximum population of country is still living in villages where transport is either bi-cycle or motorbike. Current hike rate of fossil fuel prices up to 30-40 % every year has made the situation alarming. With this pace by 2010 prices may go double than what is today and by 2030-40, it may touch to Rs.1000 per litre. A time will come when common person would not be able to purchase fuel to run the motorbike. It is not only due to rate of increase of vehicles in India, but it is a worldwide problem as 80 % of fossil fuel is being consumed in transport because of increasing mobility of persons and transportation of daily consumable materials through road transport. Thus, the need of the day is to explore possibility of alternatives for fossil fuel to make environment free from emission & make children healthy.

This paper deals with study of the contribution of Non-Conventional Energy resources such as Solar Energy, Wind Energy, Bio-mass, Bio-gas, Hydrogen, Bio-Diesel and Energy Storage System especially Compressed air to maintain energy sustainability into 21st Century . Zero pollution compressed air engine is proposed as attractive alternative. It can lead to better future both environmentally and ecologically.

2.0 SUSTAINABILITY TO ENERGY SOURCE

It is established fact that “Sustainability is nothing but meeting the needs of current and future generations through simultaneous environmental, social and economic improvement” [3]. The Sustainability to energy source is nothing but to preserve the oil and make brighter future of mankind by adding alternative energy sources such as Non-Conventional and or Renewable Energy which is going to help current problem to some extent. Now worldwide researchers and inventors are paying full attention towards this issue-

From above it is evident that there are two distinct reasons to search alternative to fossil fuel and make sustainable energy source; the first one is depletion of oil resources and other one is higher rate of emission of green house gases due to rapid use of hydrocarbon fuel.

2.1 Fossil Fuel Depletion

About 100 years ago our researches had gone towards use of hydrocarbon energy (i.e. petroleum product) as main energy source, but it is now causing civilization vulnerable due to its shortage in availability / depletion. Many researchers, technologists and scientist have asked [3, 4] as to why alternative to fossil fuel is required.

2.2 Effect on Environment and Ecology

It is observed that with increasing pace of civilization, uses of transport have become essential part of life and increasing in geometrical progression. This is leading to very hazardous condition due to high rate of pollution. Study shows that in early 1950's typical new cars were emitting nearly 13 grams per mile hydrocarbons (HC), 3.6 grams per mile nitrogen oxides (NOx), and 87 grams per mile carbon monoxide (CO). Since then, the US Government in 1995 has set standards to bring down levels of these pollutants to 0.25 gram per mile HC, 0.4 gram per mile NOx, and 3.4 grams per mile CO. The standard for evaporative HC emissions is 2 grams per test, which is being followed by all the countries of the world.

3.0 CONTRIBUTION OF NON-CONVENTIONAL ENERGY RESOURCE

Many researches are being carried out to find the alternative to fossil fuel. Apart from this the devices based on non-conventional energy such as windmills, bio diesel and di-methyl ether, hydrogen cell, photovoltaic cell, battery operated vehicles are being used as an alternative to fossil fuel.

3.1 Use of Wind Energy

Windmills are being used very effectively for irrigation as well as power generation, where high velocity air is running in atmosphere, due to geological conditions. Wind power [5] is the kinetic energy of wind, or the extraction of this energy by wind turbines. In 2004, wind farm power, became the least

expensive form of new power generation, dipping below the cost per kilowatt-hour of coal-fired plants. Wind power is growing faster than any other form of electrical generation, at about 37% up from 25% growth in 2002. In the late-1990s, the cost of wind power was about five times its cost in 2005. The downward trend is expected to continue due to mass production of multi-megawatt turbines.

According to the Global Wind Energy Council (GWEC) data [6], the US installed wind turbines of 5,244 mW capacity in 2007, which was more than double of the 2006 figure. It accounted for 30% of the country's new power producing capacity in 2007. Overall the US wind power generating capacity grew by 45% in 2007 with total installed capacity of 16,800 mW. With 8000 mW of installed capacity, India is ranked fourth in the world in total wind power capacity. About 1730 mW new capacity was added up to December- 2007.

3.2 Bio-Diesel

Biodiesel is a renewable fuel obtained from vegetable oils, animal fats, and recycled cooking oils. Biodiesel [7] offers many advantages. It can be used in several different ways such as use 1% to 2% Biodiesel as a lubricity additive. Up to 20% Biodiesel can be easily blended with 80% diesel fuel (B20) for use in most of the applications that use diesel fuel. It can even be used in its pure form (B100) while taking proper precautions.

The Bio Diesel is tested for various parameters and it is found that blending of Bio Diesel up to 18-20 % is most efficient for running of the vehicle. Also the pollution caused due to hydrocarbon (HC), carbon-mono oxide (CO) and nitrogen oxides (NOx) are found well within the emission limits prescribed by Emission Protection Act in 1995.

3.3 Di-methyl Ether

Use of Di-methyl Ether shows that CO emission is lower than Propane and n-butane over a broad range. It is also noticed that blending of 4 % oxygen by weight in the fuel can reduce emissions by as much as 28 % when compared with premium diesel [8].

3.4 Hydrogen Cell Vehicle

Hydrogen gas does not occur naturally in the Earth's atmosphere and so the gas is to be artificially produced. Currently hydrogen used in the manufacture of ammonia is produced by

reacting steam with methane. The most practical method of generating hydrogen is the electrolysis of water. This process is about 65% efficient and so the hydrogen produced this way will always be more expensive than the energy used to produce it. The recent development in Hydrogen cell car was done by USA based inventor who has demonstrated the Hydrogen Fuel Cell [9, 10] Car at 15th Annual US Conference & Hydrogen Expo, 2005 and liquid nitrogen automobiles [11], projecting the scope of its market in different country.

3.5 Photovoltaic Cell

Non-conventional energy is the source available in nature and does not cause imbalance in atmospheric ecology. Worldwide uses are being made for electric photocell to generate electric power and the power so generated is stored in batteries, which finally gives power to use it for lighting, running small electric motors, etc.. The largest PV array in the world, located in Germany [12], produces 10 megawatts of electricity.

3.6 Solar Thermal Power Generation

Solar thermal power is quietly becoming a significant source of electricity in the Southwest [13] part of world. In the desert south of Las Vegas, crews working on a project called Nevada Solar One are assembling a parabolic trough of curved mirrors connected in huge array. At the center, a closed-loop tube will be filled with oil that will be heated by the sun. The hot oil will flow around the 400-acre project and into a building where it will turn water into steam. It, in turn, will run a steam turbine for running electricity generator. This unit will produce 64 megawatts which will be enough to provide power to 40,000 homes in the Las Vegas area.

4.0 ENERGY CONVERSION AND STORAGE SYSTEM

There are two systems for energy back-up; one is Power conversion and other one is Energy storage which may provide sustainable energy and emission free environment.

4.1 Power Conversion System

The Power Conversion System (PCS) is a vital part of all energy storage systems [14]. It interfaces the energy storage, the energy storage

devices and the load (the end-user). PCS cost is significant and it can be greater than 25% of the overall energy storage system. PCS cost range from Rs.4, 000 / kW for UPS markets to Rs.48, 000 / kW for stand alone markets have been seen. Some of the major PCS markets include:

- Motor drives
- Power supplies
- UPS (uninterruptible power supply)
- Electric vehicles
- Inverters/Converters for solar-hybrid systems, Micro-turbines, Fuel cells, Wind turbines

These storage systems operate in varying environments and electrical conditions. In most of the storage systems there are many different types of Battery Technologies and with the different designs, there are advantages under specific operational conditions. It is important to understand the capabilities and limitations of each storage technology. Types of Battery Storage Technologies are listed below:-

- **Lead-Acid Battery:** It is a low cost and popular storage choice for UPS. The amount of energy (kWh) that a lead-acid battery [15] can deliver is not fixed and depends on its rate of discharge.
- **Lithium Ion Battery (Li-Ion):** The main advantages of Li-ion batteries[16], compared to other advanced batteries, are high energy density (300 - 400 kWh/m³, 130 kWh / ton), high efficiency (near 100%) and long cycle life (3,000 cycles @ 80% depth of discharge). It is preferably used in Electric Vehicles [17].
- **Sodium Sulfur Battery (NaS):** Such battery is producing about 2 volts; process is reversible and is kept at about 300° C temperature to allow this process.
- **Polysulfide Bromide Flow Battery (PSB):** It provides a reversible electrochemical reaction and produces about 1.5 volts across the membrane and battery works at room temperature.
- **Vanadium Redox Flow Battery (VRB):** The cell voltage is 1.4 -1.6 volts. The net efficiency of this battery can be as high as 85%.

4.2 Energy Storage System

Different energy storage systems are described ahead.

4.2.1 Super Capacitor

Electrochemical capacitors (EC) store electrical energy in the two series capacitors of the electric double layer (EDL), which is formed between each of the electrodes and the electrolyte ions [18]. The distance over which the charge separation occurs is just a few angstroms. The capacitance and energy density of these devices is thousand times larger than electrolytic capacitors. The asymmetrical capacitors that use metal for one of the electrodes have a significantly larger energy density than the symmetric ones and have lower leakage current.

4.2.2 Flywheels

Most modern flywheel energy storage systems [19] consist of a massive rotating cylinder (comprised of a rim attached to a shaft) that is substantially supported on a stator by magnetically levitated bearings that eliminate bearing wear and increase system life. To maintain efficiency, the flywheel system is operated in a low vacuum environment to reduce drag. The flywheel is connected to a motor / generator mounted onto the stator that, through some power electronics interact with the utility grid. Some of the key features of flywheels are little maintenance, long life (20 years or 10's of thousands of deep cycles) and environmentally inert material. The stored energy can be approximated by:

$$E = (I\omega^2)/2 = (mr^2\omega^2)/2 = (mv^2)/2$$

where ω is the rotational velocity (rad /sec), I is the moment of inertia for the thin rim cylinder, m is the cylinder mass and v is linear rim velocity.

5. 0 USE OF COMPRESSED AIR AS A 21ST CENTURY ENERGY STORAGE SYSTEM

The air engine technology is very old and was in process of development parallel to combustion technology. It is on record that Stirling air engine was developed in 1790-1810, but due to some limitations much work was not carried out. The uses of such engines are limited such as in Coal mines where fire problem are predominant and other highly flammable places where fossil fuel vehicles are not advisable to be utilized. The technology again took its rolling pace in 1979 when cost of petroleum product had

gone very high, but from 1979 to 1998 much work did not take place.

Since the last two decades lot of researches are being made to tap down air freely available in atmosphere and compressing it for storage in cylinders for its further use. This compressed air can be used to run combustion engine with mixture of gas and air getting fired at compression stroke at TDC. Compressed air helps for fire stroke when ignition takes place. Thus, efficiency of IC engine gets improved and without running all four stroke cycle it runs on two stroke cycle. The air engines so far developed [20, 21] are basically running on hybrid system such as compressed air and gases and such engines are not 100% zero pollution.

5.1 Availability of Air

Air is natural source and available freely in atmosphere, which can be stored after compressing it to desired pressure such as 90-350 psi. This is the only source, which can be stored at very high pressure and can be retained without any loss after lapse or with passage of time. Compressed air can drive many domestic appliances such as vacuum cleaner, mixers, pumps, electric generator when electric power fails instead of using inverter to have clumsy arrangements of battery etc.

5.2 Sustainability, Economics and Advantages

Compressed air is most sustainable. It has no volatility or temperature or much weather effect. Once compressed air is stored through compressor, it will be available at any time without any loss of pressure. Thus sustainability of compressed air is much better compared to other available alternate of fossil fuel. Battery needs constant maintenance even for charging & discharging cycle. Hydrogen Cell is very costly due to its storage problems. Wind Mills, Photo Cells also need some storage devices such as high bank capacitors or batteries, which will need constant and recurring expenditures on its upkeep.

5.3 Influences on Environment and Ecology

Compressed air as an alternate for running light vehicles using air turbine will have no ill effect on ecology and reduce the health hazards.

6.0 UTILIZATION OF COMPRESSED AIR AS AN ALTERNATIVE TO FOSSIL FUEL

Compressed air can be suitably used as working fluid for running air engines. These engines running on compressed air will have no emission and be environment friendly. There is need of devising efficient compressed air engine so that maximum specific power could be produced. Such compressed air engine will have requirement of compressors for producing compressed air as working fluid. Thus there are two issues, one for developing an efficient compressed air engine and other one to have efficient compressor & air storage system. In this area development of air engines are being made very fast. Some of the major works done by different researchers in this area so far are detailed below with respect to their names.

6.1 “Guy Negre”

A French Scientist ‘Guy Negre’, in 1998 developed compressed air 4-cylinders engine run on air and gasoline, claims zero pollution cars and got 52 - patents registered since 1998 to 2004. The car was publically demonstrated in Oct. 2004 [20].

6.2 “Beau De Rocha (OTTO)”

A Korean inventor ‘Beau De Rocha’ developed zero pollution cars using Quasiturbine with a set of 14-engines parameters and disclosed it on September 2005 using gasoline [21].

6.3 “Singh B.R. And Singh Onkar”

An air turbine is being developed which can be used as prime-mover to light vehicle or motor-bike efficiently [22-23]. The high pressure compressed air works as the driving force at ambient temperature. The impulse and dynamic action due to high pressure are responsible for the shaft work. It is a reverse process of vane type air compressor and isentropic expansion is considered to develop power in this cycle.

6.3.1 Model of Air Turbine

Present objective is to develop an air engine using air turbine with output of 6.85 HP to 7.20 HP (5-5.3 kW) at 1500 to 3500 rpm, which will be suitable for a motorbike. Various steps involved in the development of engine are as given separately. A cylinder of compressed air is proposed to have minimum capacity of storing air for requirement of 30 min running at initial

stage and maximum pressure of 200-300 psi (13-20 bars approx.). The Air Turbine with dual inlet and exhaust has been taken into consideration to produce high rpm to match 3500-7000 rpm.

Compressed air storage cylinder is designed so that it produces constant delivery pressure for minimum variation of torque even at low volume of compressed air. A spring loaded baffle is installed into the cylinder to regulate the constant air pressure. The Air Turbine is designed with spring-loaded vanes to maintain regular contact with elliptical bore, to produce optimum torque [24-27].

Above air turbine is being designed to meet all the minimum operating requirements of motorbike to have efficient and fossil fuel free running.

6.3.2 Design considerations for Air Turbine

Empirical Requirements

Running Air pressure: 60-150 psi (2-10 bars) (assumed)

*Speed: 3000 rpm

*Torque: 9.6-10 Nm

P-V Ratio: 4 / 5

Note: - *Data based on Performance of commercially available motorbike (7.2 HP or 5.3 kW)

Principle

As stated above, for running novel air turbine, high pressure air is the driving force at ambient temperature. The impulse and dynamic action of high pressure are responsible to develop the shaft work. It works on reverse - process of vane type air compressor. The compressed air entering the air turbine Fig.1, having 'n' vanes, produces work due to positive displacement and expansion.

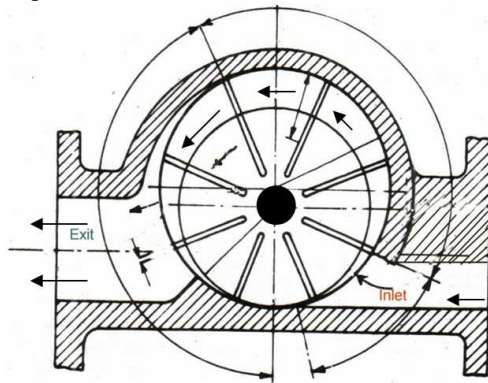

Fig.1 Vane Type Air Turbine

The expression for work is given as under: -

$$w = n \left(\frac{\gamma}{\gamma-1} \right) p_1 v_1 \left\{ \left(\frac{p_4}{p_1} \right)^{\frac{\gamma-1}{\gamma}} - 1 \right\} - n (p_4 - p_5) v_4 \quad \rightarrow (1)$$

Where w = Theoretical Work done,

p_1 & v_1 are Pressure & Volume respectively at which air strike the Turbine,

p_4 & v_4 are Pressure & Volume, respectively at which maximum expansion of air takes place,

p_5 is the Pressure at which Turbine releases the air to atmosphere.

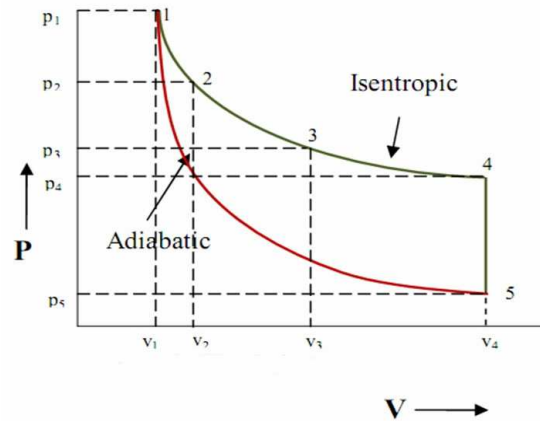

Fig.2 Isentropic Expansion Curve

From the Fig.2, it is apparent that to optimize the shaft work exit pressure p_4 must be either equal or closer to atmospheric pressure p_5 . Many parameters have been studied to get optimum shaft work. It is also evident from equation (1) that if the negative forces acting due to higher pressure difference between p_4 to p_5 are almost eliminated (i.e. $p_4 = p_5$), it will satisfy the optimal condition. A dual inlet & dual exit air turbine is designed and is under test. The Ist stage exit pressure p_4 is fed to IInd stage as inlet pressure and the IInd stage exit pressure is considerably reduced & close to atmospheric pressure p_5 . Such air turbine works at optimal conditions and becomes a novel turbine. This turbine may be used as prime mover to run light transport vehicle and is still under the process of development and investigation.

6.3.3 Cost Comparison

In case the compressed air is being used in place of fossil fuel, the air is freely available in atmosphere and offers zero cost of basic working fluid and the cost involvement in its compression is also nominal. The costing analysis for the vane air turbine based engine under study is as detailed below;

- Cost of 10 to 15 HP(7.4-11 kW) electric motor coupled with 2-3 stage compressors: Rs. 25,000.00
- Cost of electricity for filling the compressed air cylinder once*: Rs. 5.00 to Rs. 7.00
 - * - Consumption of electric power for running it for 5-10** min to fill the cylinder of 1.2 m long & 0.65 m dia at 15-20 bar (225 – 300 psi) may cost {(10 kwh X Rs 4.00# to 5.00#) . (8min**average / 60 min) = (Rs.5.00 to 7.00) including depreciation, running and maintenance of compressor devices.
 - # - Cost of electricity per unit in Rupees
- Compressed air cylinder once filled can run vehicle up to: 40 km
- Cost of running vehicle per km using compressed air: Re. 0.12 to Rs. 0.17
- Present cost of running vehicle per km using hydrocarbon fuel : Re. 0.62 to Rs. 0.75

This shows that the motor bike may run 40 km in Rs.5.00 to Rs. 7.00, where as cost of same travel distance with hydrocarbon fuel may be around Rs. 25.00 to Rs.30.00 and hence compressed air cost is almost one fifth of fossil fuel cost. On other hand in the absence of fossil fuel combustion, air as working fluid offers advantage of giving zero pollution engines. Thus the use of compressed air is economical too apart from being environmental friendly.

7.0 CONCLUSIONS

In view of fast depleting fossil fuel reserves and growing energy requirements, it has become inevitable to look for alternative sources of energy. Biodiesel, Solar Energy, Wind Energy, Photovoltaic Cell etc. have immense potential for being used as an alternative to fossil fuel but the success of future technology will depend on Energy Storage System. From present study, following conclusions are drawn:-

- Solar Energy Power Stations, Wind Power Stations and Nuclear Power

Stations will become future power generation source in big way.

- The atmospheric air having enormous potential as working fluid, can be compressed and stored in a Energy Storage Tank / Container and shall be utilized in the new transport technology of 21st century, which will reduce the tail pipe emission and thereby the environmental and ecological problems to great extent.
- Compressed air driven engines will offer attractive alternative to meet the forthcoming fossil fuel crisis, as air is the best energy carrier.

REFERENCES

- [1]. Hubbert M.K., 1956, "Peak Oil Curve"- US Geologist, Web: <http://www.hubbertpeak.com/de/lecture.html> .
- [2]. Aleklett K. and Campbell C.J., 2004, "The Peak and Decline of World Oil and Gas Production" – Oil Production-Feb.2004.
- [3]. Architectural Institute, 2004, "Concept and Technology"- First International Workshop on Sustainable Habitat Systems - Kyushu Branch, Japan - December, 10, 2004 (10:00- 18:00), Venue: ACROS Fukuoka.
- [4]. THE PLANNING GROUP, 2002, "Sustainable & Land Development Study", ENV. Australia.
- [5]. ABI Research, 2004, "Wind Turbines" - Market Wire, NY- March'16th 2004.
- [6]. Joseph Vackayil, 2008, "India ranked fourth in the wind energy Map", The Financial Express-Friday, February 08, 2008.
- [7]. Singh B.R. and Singh Onkar, 2006, "Necessity & Potential for Bio-Diesel Use in India" - International Conference Bio-Fuel Vision-2015 at Bikaner, India on October' 13th -15th, 2006- Proceeding pp 71.
- [8]. C. Gray and G. Webster, 2001, "A Study of Dimethyl Ether (DME) as an Alternative Fuel for Diesel Engine Applications", prepared by CANMET Energy Technology Centre, Natural Resources Canada and Transportation

- Development Centre, Transport Canada- in May'2001.
- [9]. Honton E. J., 2004, "The Hydrogen Fuel Cell Car" presented at 15th Annual US Conference & Hydrogen Expo-2005-USA.
- [10]. Rose Robert, William J. Vincent, 2004, "Fuel Cell Vehicle World Survey 2003"- Break through Technologies Institute, Washington, D.C.
- [11]. Knowlen C., Bruckner A. P., Mattick A.T., and Hertzberg A., 1998, "High Efficiency Energy Conversion Systems for Liquid Nitrogen Automobiles"- Society of Automotive Engineers Inc., AIAA vol. 98-pp1898.
- [12]. Renewable News, 2006," World's biggest solar electric plant opens in Germany", Deutsche Presse- Agentur, Sep 1, 2006, 16:51 GMT. Web: http://www.monstersandcritics.com/news/energywatch/renewables/news/article_1196942.php
- [13]. Ted Robbins, 2006, "Solar Power on a Massive Scale" Morning Edition, August 30, 2006 Web: <http://www.npr.org/templates/story/story.php?storyId=5733830>
- [14]. Govt. of WA, 2002, "Focus on the Future Sustainable & Land Development Study"- The Western Australian State Sustainability Strategy - Consultation Draft, 2002, pp.8.
- [15]. Martha, S.K., Hariprakash, B., Gaffoor, S.A., Trivedi, D.C., and Shukla, A.K., 2006, "A low-cost lead-acid battery with high specific-energy", Journal of Chemistry Science, Vol. 118, No. 1, February 2006, pp. 93-98.
- [16]. Chrisitan Julien, Pereira-Ramos, J. P., Momchilov, A., 2002, "New Trends in Intercalation Compounds for Energy Storage", Science -Pp 654.
- [17]. Gene Berdichevsky, Kurt Kelty, Straubel, J.B., and Toomre Erik, 2006, "The Tesla Roadster Battery System" Tesla Motors, August 16, 2006.pp1-5.
- [18]. Capacitor Energy Storage, "Electricity Storage Association" web: http://www.electricitystorage.org/tech/technologies_technologies.htm
- [19]. Atcity, S., Ranade, S., Gray-Fenner, Amber , 1998, "Summary of State-of-the-Art Power Conversion Systems for Energy Storage Applications"- Sandia National Laboratories - Report SAND98 - 2019
- [20]. Negre Guy and Negre Cyril, 2004, "Compressed Air - The Most Sustainable Energy Carrier for Community Vehicles", - Speech in front of assembly at Kultur gathered for "Fuel Cells World" Tuesday 29th June'20004.
- [21]. Rocha Beau de (Otto), 2005, "Quasiturbine zero pollution cars using gasoline" -25th Sept'2005 at Korea.
- [22]. Singh B.R. and Singh Onkar ,2006, "Compressed air as an alternative to Fossil Fuel for Automobile Engines" Proceedings of International Conference on 'Challenges and Strategies for Sustainable Energy, Efficiency and Environment' at Lucknow, India on 10th-11th June, 2006 - pp 179-191.
- [23]. Singh B.R. and Singh Onkar, 2008, "Development of Novel Air Turbine" International Conference at Honolulu, Hawaii-on 17th-22nd Feb, 2008; Paper No. ISROMAC 12-2008-20046.
- [24]. Schreck S. and Robinson M., 2004, "Tip Speed Ratio Influences on Rationally Augmented Boundary Layer Topology & Aerodynamic Force Generation" - Journal of Solar Energy Engg.-Vol.126 pp1025-1033.
- [25]. Selig Michel S., 2004, "Wind Tunnel Aerodynamics Tests of Six Airfoils for use on Small Wind Turbines" -ASME- Nov'2004.
- [26]. Fuglsang P., Bak C., Gunna M, 2004, "Design and verification of the Ris0-B1 Airfoil-family for Wind Turbines". ASME- Nov'2004, Vol.126 pp 1002 - 1008.
- [27]. Gorla Rama, Subba Reddy, 2005, "Probabilistic Heat Transfer and Structural Analysis of Turbine Blade" - IJTJE - Vol. 22, pp 1- 11.